

THE FIG LEAVES

اوراق التين

THE PRODUCT LINE

By Racha Tarazi

THE PHILOSOPHY

WITH MY OWN MEMORIES AND STORIES I STARTED GROWING FIG TREES

On the street where I grew up there was a huge fig tree. Every time I passed underneath it, I would stop and look at it. I was always told not to touch it and then rub my eyes, but I never listened. I always had an urge to pat the leaves and explore even more. Why has this tree fascinated me ever since I was a child? Fig leaves are not like any other leaves they have very rounded edges and they are full, juicy and velvety. They are different in their elegant suspension, their bounciness and young nature. Even their veins are exceptional—they are so prominent and alive. These characteristics are what make it so unique and vibrant. Whenever I stood under the tree and looked up inside it, I became a child who wanted to jump, celebrate and play along with all the moving leaves. This happy energy invigorated me and played a big part in extending my imagination beyond what is grown in nature.

The sounds and stories that I could see and hear within the fig tree inspired me. I wanted to recreate my interaction with the tree and celebrate and share it with my world.

From my stories I began growing fig trees of my own imagination. I began thinking, “What if the relationship between each leaf was different?” and “What if I reinvent their connections?” And I even thought, “What if they interlock with my own narrative?” The image in my head began to form and it felt like embroidery, or stitching. I realized that I was beginning to build an interlocking story of my own through my creative process. And I could not stop! My trees are different from the one that grew on my street in that they are abstract and have other functions. They grow in our living spaces. Every piece adapts to its owner’s stories, and their personality changes as they move into new homes.

FIG BOWLS

DECORATIVE OBJECTS

HAND MADE FROM
GRADE A STAINLESS STEEL



FIG BOWL ENERGETIC

JD 230

Decorative Bowl,
18/10 brushed stainless steel
L34 x W30 x H09 cm



FIG BOWL ENERGETIC MINI

JD 85

Decorative Bowl,
18/10 brushed stainless steel
L20 x W22 x H09 cm



FIG BOWL SWIFT LARGE

JD 350

Decorative Bowl,
18/10 brushed stainless steel
L57 x W57 x H07 cm



FIG BOWL SWIFT MEDIUM

JD 230

Decorative Bowl,
18/10 brushed stainless steel
L55 x W40 x H04 cm

FIG LIGHTS

AMBIENT EXPERIENCE

HAND MADE FROM PLEXIGLASS AND
GRADE A STAINLESS STEEL

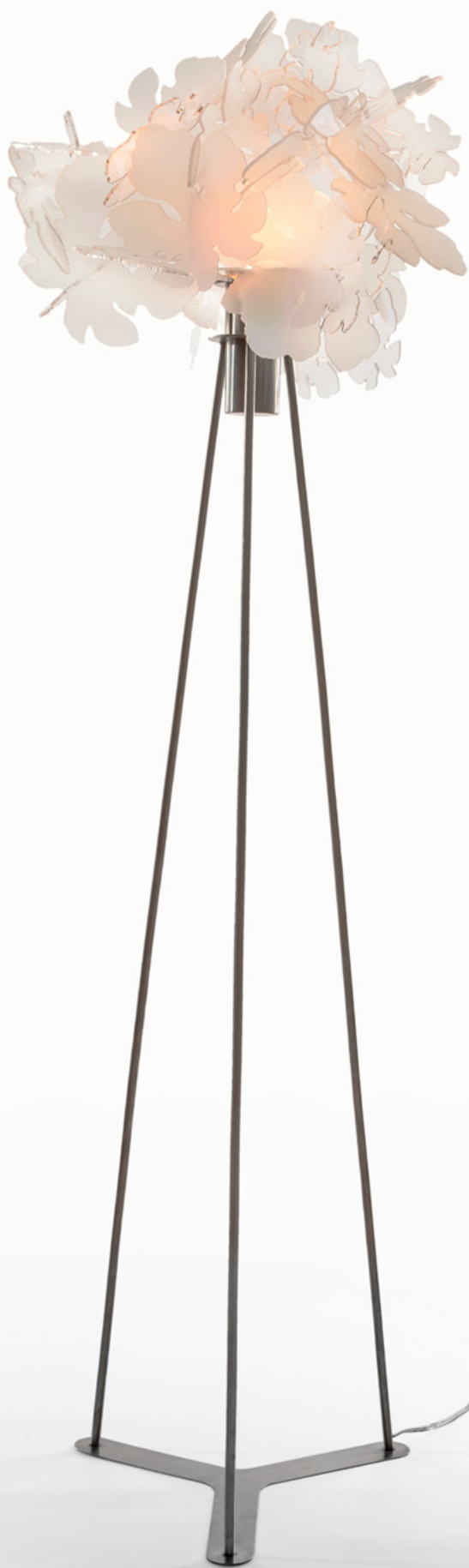

FIG LIGHT TALL

JD 475

Ambient Light in 2mm
Plexi and stainless steel
W46x H140cm



FIG LIGHT SHORT

JD 450

Ambient Light in 2mm
Plexi and stainless steel
W48x H45cm

FIG LIGHT TALL

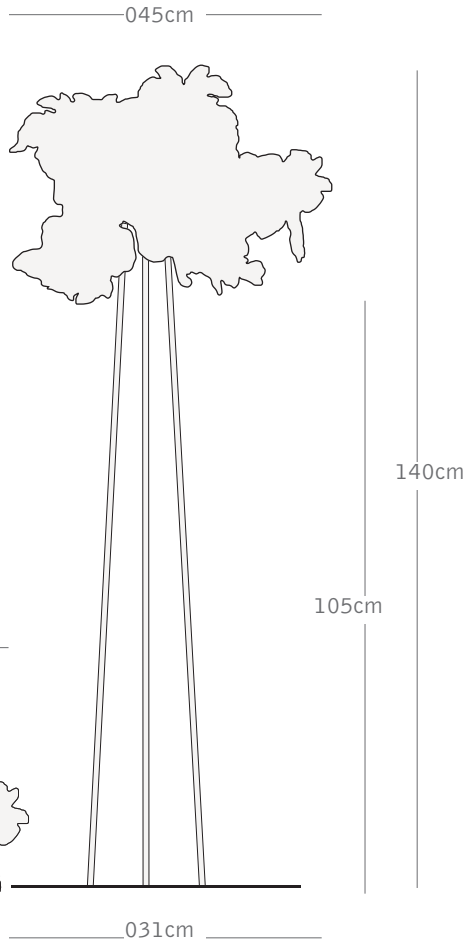

FIG LIGHT SHORT

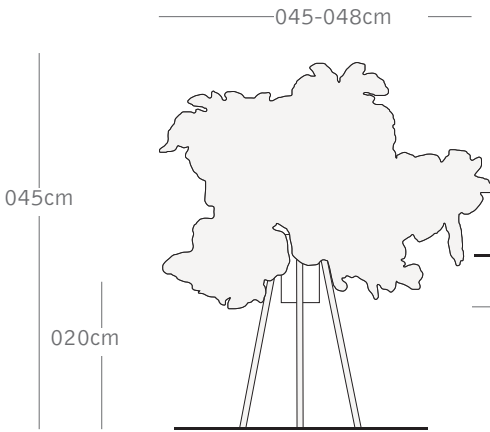

FIG LIGHT MINI

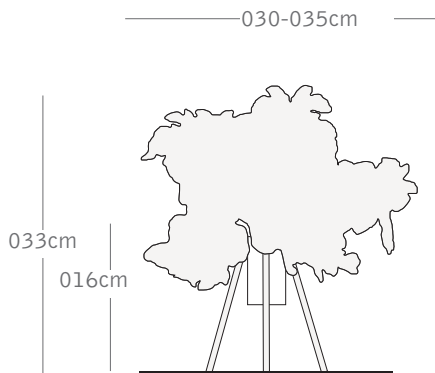

FIG LIGHT MINI

JD 200

Ambient Light in 2mm
Plexi and stainless steel
W30x H35cm

FIG FASHION PENDANT NECKLESS

HAND MADE FROM STAINLESS STEEL
WITH SILVER CHAINS



ENERGETIC NECKLACE

JD 60

18/10 Polished stainless steel
with silver chain

FIG COLLECTION
IN CONTEXT



FIG LIGHT TALL

Ambient Light in 2mm
Plexi and stainless steel
W46x H140cm



FIG LIGHT SHORT

Ambient Light in 2mm
Plexi and stainless steel
W48x H45cm



FIG BOWL SWIFT MEDIUM

Decorative Bowl,
18/10 brushed stainless steel
L55 x W40 x H04 cm

SUPPORTING LOCAL CRAFTS

DESIGNED AND HANDCRAFTED IN JORDAN FROM GRADE (A) STAINLESS STEEL

All of the fig leaves products are handmade utilizing Jordanian resources together with the handcrafts of the artists herself.

Although designed to be functional products, the Fig Leaves line chose hand made production rather than machines, with the intention of supporting the environment and helping local resources find venues to express their work globally.



ORDERS DETAILS

READY TO ORDER? THANK YOU FOR YOUR INTEREST IN FIG LEAVES PRODUCT LINE

The product line is all hand made and requires time to produce. If you are interested in purchasing any of our items, the time to deliver is two to three weeks.

SEND ME THE PRICE LIST

Please email us your country and what you are interested in and we will send you accurate price lists.
Email: rachatarazi@gmail.com

JUST PLACE AN ORDER

You can place an order by email or phone:
Email: rachatarazi@gmail.com
Mobile: +962 (0) 795724149

Please add your notes carefully in the email.

A GIFT?

Speical wrapping and card is available.

TRAVELING OR SHIPPING?

We can bubble wrap the bowl and the box.



UNIQUE READY TO GIFT
GREEN PACKAGING



- Environmentally friendly designers box
- Protective tissue paper (bubble rap if requested)
- The Story within a booklet of products
- Tag

ABOUT THE DESIGNER



Racha Tarazi is a cross media experience designer. She studied Architecture then completed an MFA in Design and Technology from Parsons School of Design, NYC. She worked as an architect and an information architect then moved to NYC where she worked as an interaction designer for the award-winning digital agency R/GA NYC and London. She also taught

design at Parsons School of Design in NYC.

Racha saw the value of crossing cultures and carried her experience as an independent consultant in Experience Design and building new brands/products between NYC, and Jordan.

She founded M-E Living Amman, the first boutique designed objects store with a gallery atmosphere. Led Design Jordan; a pioneering design studio focused on product innovations.

Currently resides in Amman, focusing on new innovative products inspired from local elements but reflect a new global living.

Her work was exhibited at different venues:

-2011, May: "The Fig Leaves Collection" Exhibited at the Wine Maker Gallery, Amman

-2010 "Change by Design" Exhibition at Design Jordan Studio, Amman. Exhibited unique products from Lighting fixtures inspired by arabic calligraphy, to a new innovative Arabic coffee pot.

-2003 "Disconnected >< Reconnected: Play in the office space" was shown at Parsons Gallery, NYC. The piece used digital technologies to create a playful visualization, which explores the relationship between tacit knowledge sharing and face-to-face interaction in the office space.

-2003 "Architectural Intervention" an installation which played with the concept of reactive architecture was on exhibit in Parsons Gallery, NYC. The work was published in Metropolis Magazine, March 2003.

-2000 "The Story of the Village of Dana," Hanover Germany. An environmental experience part of the Jordanian Pavilion.